

DEPARTMENT OF THE ARMY TECHNICAL MANUAL

**DS, GS, AND DEPOT MAINTENANCE MANUAL, POWER
SUPPLIES PP-1209/FG, PP-1209A/FG, PP-1209B/FG,
AND PP-1209C/FG**

Headquarters, Department of the Army, Washington, D.C. 20315
2 May 1966

WARNING

Dangerous voltages exist in this equipment. Be careful when working on the power supply circuits or the 115-volt ac line connections. Serious injury or death may result from contact with these points.

Power Supply PP-1209/FG contains selenium rectifiers which release poisonous compounds and fumes when they burn out or arc over. If this happens, provide adequate ventilation immediately and do not handle the rectifier until it cools. The fumes have a strong odor and are toxic; permanent injury or death could result from prolonged inhalation.

DON'T TAKE CHANCES

	Paragraph	Page
CHAPTER 1. INTRODUCTION		
Scope	1-1	1-1
Index of publications	1-2	1-1
Internal differences in models.....	1-3	1-1
2. FUNCTIONING OF POWER SUPPLY PP-1209(*)/FG		
General	2-1	2-1
Circuit analysis	2-2	2-1
3. DIRECT SUPPORT MAINTENANCE		
Section I. Troubleshooting techniques		
General instructions	3-1	3-1
Organization of troubleshooting procedures	3-2	3-1
Test equipment required	3-3	3-1
Visual inspection	3-4	3-2
Troubleshooting chart	3-5	3-2
Isolating trouble within plug-in unit	3-6	3-3
II. Repair		
General parts replacement techniques	3-7	3-7
Testing repaired equipment	3-8	3-7
CHAPTER 4. GENERAL SUPPORT TESTING PROCEDURES		
General support testing procedures	4-1	4-1
Test Equipment and other equipment	4-2	4-1
Test facilities	4-3	4-2

*This manual, together with TM 11-7807-239-12, 4 October 1962, supersedes TB SIG 284, 25 June 1956; including C1, 30 September 1957; C2, 9 June 1958; C3, 16 November 1960; C4, 12 March 1963; and C5, 27 December 1963.

	Paragraph	Page
CHAPTER 4. Modification work orders -----	4-4	4-2
Cont. Physical tests and inspection -----	4-5	4-3
Output votlage test- -----	4-6	4-5
Test data summary -----	4-7	4-6
CHAPTER 5. DEPOT INSPECTION STANDARDS		
Applicability of depost inspection standards -----	5-1	5-1
Applicable references -----	5-2	5-1
Test facilities required -----	5-3	5-1
General test requirements -----	5-4	5-2
Operational test -----	5-5	5-2
APPENDIX REFERENCES -----		A1-1

CHAPTER 1

INTRODUCTION

1-1. Scope

a. This manual covers the direct and general support maintenance of Power Supplies PP-1209/FG, PP-1209A/FG, PP-1209B/FG, and PP-1209C/FG. It includes instructions for troubleshooting and repairing the equipment, for replacing maintenance parts, and for testing the equipment after repair for return to service. It also lists the tools and test equipment required for direct support, general support, and depot maintenance. The functioning and circuit analysis of the equipment are described in chapter 2.

b. The operating instructions, the maintenance allocation chart, and the basic issue items list for this equipment are contained in TM 11-5805-239-12.

c. Official nomenclature followed by (*) is used to indicate all models of the equipment item covered in this manual. Thus, Power Supply PP-1209(*)/FG represents Power Supplies PP-1209/FG, PP-1209A/FG, PP-1209B/FG, and PP-1209C/FG.

d. The complete technical manual for this equipment includes TM 11-5805-239-12, TM 11-5805-239-12P, and TM 11-5805-239-35P.

e. The direct reporting of errors, omissions, and recommendations for improving this equipment manual by the individual users is authorized and encouraged. DA Form 2028 will be used for reporting these improvements. This form may be completed by the use of pencil, pen, or typewriter. DA Forms 2028 will be completed by the individual using the manual, and forwarded direct to Commanding General, U.S. Army Electronics Command, AMSEL-MR-(NMP)-MA, Fort Monmouth, New Jersey 07703.

1-2. Index of Publications

Refer to the latest issue of DA PAM 310-4 to determine whether there are new editions, changes, or additional publications pertaining to this equipment. The index lists the individual parts (-12, -35, etc) and the latest changes to and revisions of each equipment publication.

1-3. Internal Differences in Models

The internal differences are listed in one chart below. For external and other internal differences see TM 11-5805-239-12.

Item	PP-1209/FG (Order No. 26331-Phila-55)	PP-1209/FG (Order No. 42902 Phila-57)	PP-1209A/FG	PP-1209B/FG	PP-1209C/FG (Order No. 10473-PP-61-C2-C2)	PP-1209C/FG (Order No. 20291-PP-62)
Input terminal board TB2.	Eight-terminal terminal board used.	Not used.	Not used.	One-terminal terminal board used.	Same as model B.	Same as model B.
Output terminal board TB1.	Mounted at side of main chassis assembly.	Mounted at rear of main chassis assembly.	Same as on Order No. 42902-Phila-57.	Same as model A.	Same as model A.	Same as model A.
Terminal board TB3 (p/o plug-in unit).	Not used.	Not used.	Used to mount rectifier CR1.	Not used.	Not used.	Not used.
Ac input cable ----	Connected at input terminal board TB2.	Live side soldered to terminal of fuseholder for ac input fuse F2, and GRD side soldered directly to terminal 3 of jack J2.	Same as PP-1209/FG (Order No. 42902-Phila-57).	Soldered to terminal of fuseholder for ac input fuse F2 and terminal of input terminal board TB2.	Same as model B.	Same as model B.
Rectifier CR1. ----	Selenium-type used.	Selenium-type used.	Diode semiconductor (silicon-type) used.	Same as model A.	Same as model A.	Same as model A.
Resistor R2 (p/o plug-in unit).	5-ohm resistor.	5-ohm resistor.	5-ohm resistor.	10-ohm resistor.	Same as model B.	Same as model B.
Resistor R4. -----	Not used.	Not used.	Not used.	Used on equipment modified by MWC 11-5805-239-35/1	Same as model B.	Same as model B.
Capacitor retainer (p/o plug-in unit).	Not used.	Not used.	Not used.	Used to mount capacitor C1.	Not used.	Not used.
Retaining strap for plug-in units.	Not used.	Not used.	Not used.	Not used.	Not used.	Used.
Blown-fuse indicator.	White.	White.	White.	Red.	Red.	Red.
Circuit wiring ----	Figure 5-1.	Figure 5-1.	Figure 3-1.	Figure 3-1.	Figure 3-2.	Figure 3-1.

CHAPTER 2

FUNCTIONING OF POWER SUPPLY PP-1209(*)/FG

2-1. General

Power Supply PP-1209(*)/FG is a rectifying unit that converts 105-115-volt, 60-cycle-per-second (cps), single-phase alternating current (ac) to pulsating direct current. It consists of a main chassis assembly and eight plug-in units. Each plug-in unit contains a half-wave rectifier circuit that receives its ac input from a common ac input circuit in the main chassis assembly, and provides a separate (either positive or negative) dc output. Each dc output is individually adjustable from 0 to 100 milliamperes (ma) at voltages that vary from approximately 155 volts at 0 milliampere to approximately 129 volts at 100 milliamperes. The polarity of the dc output of each individual plug-in unit is determined by the position in which it is plugged into the main chassis assembly.

2-2. Circuit Analysis (fig. 2-1)

The PP-1209(*)/FG is connected to a 105- to 125-volt ac supply by polarized plug P3 and the, ac input cable. The live side of the ac input is applied through ac input fuse F2 to terminal 7 of each jack J1 and J2 of the main chassis assembly. (Terminals 7 of all jacks J1 and J2 are connected in parallel.) The polarity of the dc output of each plug-in unit depends on whether its plug connector P1 is connected to jack J1 or jack J2. When plug connector P1 is connected to jack J2, the dc output is positive. When plug connector P1 is connected to jack J1, the dc output is negative. Plug P2 of each plug-in unit is a dummy. (unwired) plug. The functioning of one of the eight circuits of the power supply is: described in *a* and *b* below. The other seven circuits consist of identical parts, and function in the same manner.

a. Positive Dc Output. When plug-in unit plug P1 is connected to jack J2 of the main chassis assembly (with the word POSITIVE at the top), the circuit is arranged as a half-

wave rectifier in which current flows only during the positive half-cycles of ac input (A of fig. 2-1). During these half-cycles, the electron current flows from the grounded side of the ac input line, through the grounded load to output terminal board TB1, output current control resistor R3, dc output fuse F1, output current-limiting resistor R1, rectifier CR1, input current-limiting resistor R2, terminal 7 of jack J2, and input fuse F2, to the live side of the input ac line. Output current control rheostat R3 is an adjustable resistance that controls the value of the output dc available at terminal board TB1. Blown-fuse indicator DS1 is connected in parallel with dc output fuse F1, and lights when F1 is blown or missing from the circuit. Capacitor C1 filters the dc output. Bleeder resistor R4 (used in PP-1209B/FG modified in accordance with MWO 11-5805-239-35/1, and PP-1209C/FG) dissipates the charge on C1 when the plug-in unit is removed from the main chassis assembly. Resistor R4 is connected between terminals 3 and 4 of plug P1.

b. Negative Dc Output. When plug-in unit plug P1 is connected to jack J1 of the main chassis assembly (with the word NEGATIVE at the top), the circuit is arranged as a half wave rectifier in which current flows only during the negative half-cycles of the ac input. During these half-cycles, the electron current flows from the live side of the ac input line, to input fuse F2, input current-limiting resistor R2, rectifier CR1, output current-limiting resistor R1, output fuse F1, output, current control rheostat R3, terminal board TB1, and to the load which completes the path to the grounded side of the input ac line.

Notes

1. Power supplies having order No. 10437-PP-61-C2-C2 have all circuits reverse-wired with respect to all other order numbers (fig. 3-2).

2. Power Supplies PP-1209B/FG that have been modified by MWO 11-5805-239-35/1, and PP-1209C/FG have bleeder resistor R4 connected across capacitor C1.

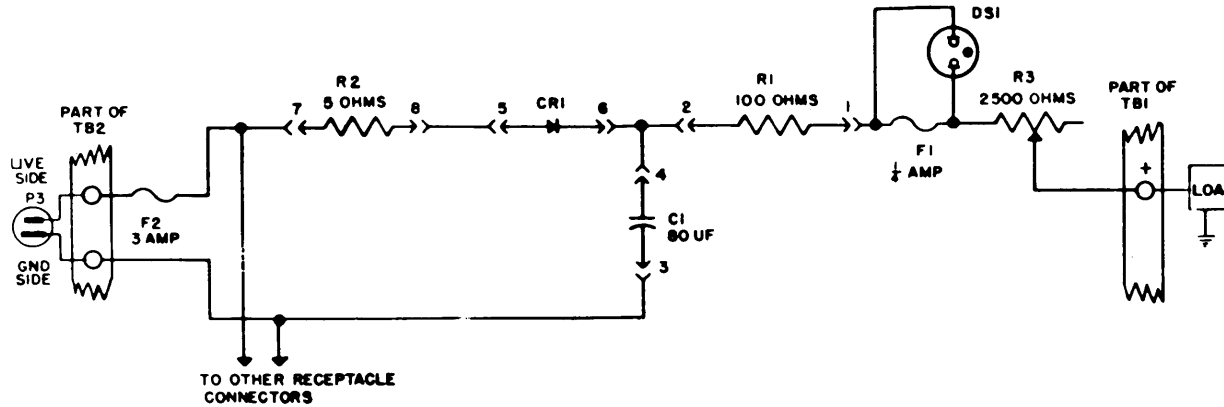

A. PLUG-IN UNIT CONNECTED FOR POSITIVE DC OUTPUT

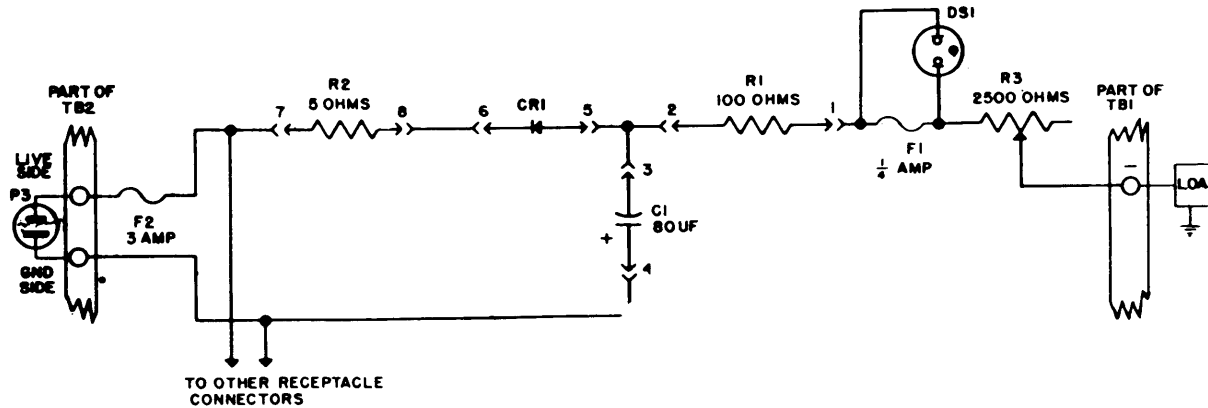

B. PLUG-IN UNIT CONNECTED FOR NEGATIVE DC OUTPUT

NOTES:

- 1 AU PLUG AND JACK TERMINALS SHOWN ARE TERMINALS OF PLUG PI AND JACK J2.
- 2 JACK J1 NOT USED IN THIS CIRCUIT.
- 3 ON POWER SUPPLY PP-1209/FG, ORDER NO. 42902-PHILA-57, TERMINAL BOARD TB2 IS NOT USED.
- 4 ON POWER SUPPLY PP-1209B/FG, TERMINAL BOARD TB2 HAS ONLY ONE TERMINAL; THE GROUND SIDE OF THE AC INPUT CABLE IS SOLDERED TO THIS TERMINAL. THE LIVE SIDE OF THE AC INPUT CABLE IS SOLDERED TO ONE TERMINAL OF THE FUSE HOLDER FOR AC INPUT FUSE F2.
- 5 ON POWER SUPPLY PP-12098/FG RESISTOR R2 IS 10 OHMS.
- 6 ON POWER SUPPLY PP-1209B/FG, PLUG - IN UNITS THAT HAVE BEEN MODIFIED IN ACCORDANCE WITH MWOII-S605-239 - 35/1 HAVE 27,000-OHM RESISTOR R4 CONNECTED IN PARALLEL WITH CAPACITOR C1 BETWEEN CONTACTS 3 AND 4 OF PLUG PI.

NOTES:

- 1 ALL PLUG AND JACK TERMINALS SHOWN ARE TERMINALS OF PLUG PI AND JACK J1
- 2 JACK J2 NOT USED IN THIS CIRCUIT.
- 3 ON POWER SUPPLY PP-1209/FG ORDER NO. 42902-PHILA-57, TERMINAL BOARD TB2 IS NOT USED.
- 4 ON POWER SUPPLY PP-1209B/FG, TERMINAL BOARD TB2 HAS ONLY ONE TERMINAL; THE GROUND SIDE OF THE AC INPUT CABLE IS SOLDERED TO THIS TERMINAL. THE LIVE SIDE OF THE AC INPUT CABLE IS SOLDERED TO ONE TERMINAL OF THE FUSE HOLDER FOR AC INPUT FUSE F2.
- 5 ON POWER SUPPLY PP-1209B/FG, RESISTOR R2 IS 10 OHMS.
- 6 ON POWER SUPPLY PP-1209B/FG, PLUG - IN UNITS THAT HAVE BEEN MODIFIED IN ACCORDANCE WITH MWOII-58-9 -35/1 HAVE 27,000-OHM RESISTOR R4 CONNECTED IN PARALLEL WITH CAPACITOR C1 BETWEEN CONTACTS 3 AND 4 OF PLUG PI

Figure 2-1. Power Supply PP -1209(*)/FG, schematic diagram (all models except Order No. 10473-PP-61XM9).

CHAPTER 3

DIRECT SUPPORT MAINTENANCE

Section 1. TROUBLESHOOTING TECHNIQUES

3-1. General Instructions

The systematic troubleshooting procedures, which begin with the operational troubleshooting checks that are performed at an organizational level, are carried to a higher level in this chapter. These procedures are more advanced and require more test equipment and material. If visual inspection of the defective plug-in power supply and the main chassis fails to determine the cause of trouble, localization and isolation procedures are required.

3-2. Organization of Troubleshooting Procedures

a. General. The first step in servicing a defective power supply is to sectionalize the fault. Sectionalization means tracing the fault to a major component. The second step is to localize the fault. Localization means tracing the fault to a defective part responsible for the abnormal condition. Some faults, such as burned-out resistors arcing, and shorted transformers can often be located by sight, smell, and hearing. The majority of faults, however, must be isolated by checking voltages and resistances.

b. Sectionalization. Paragraph 3-5 lists a group of tests arranged to reduce unnecessary work, and the aid in tracing trouble in a defective Power Supply PP-1209(*)/FG. The first step is to locate the unit or units at fault by means of a visual inspection. The

purpose of visual inspection is to locate faults without testing or measuring circuits. All visual signs should be observed and an attempt made to sectionalize the fault to a particular unit.

c. Localization. Localization consists of those procedures performed by direct support maintenance personnel to determine the general area of trouble. If a plug-in unit is faulty, replace the entire unit. Use the troubleshooting chart (para 3-5) and the operational test (para 3-8) to localize a fault.

d. Isolation. Isolation procedures are used by direct support maintenance personnel to find a faulty part of the plug-in unit (para 3-6). When a defective part has been isolated, replace the part.

3-3. Test Equipment Required

The chart below lists the test equipment required for troubleshooting Power Supplies PP-1209(*)/FG. Also listed are the associated technical manuals.

Warning: In power supplies that do not have MWO 11-5805-239-35/1 applied, capacitor C1 will be fully charged to the dc output voltage. Use a test lead with an alligator clip to discharge C1 as follows: Attach the alligator clip to the short probe, and clamp the alligator clip to terminal 4 of plug P1. Place one hand in your pocket and touch the long probe to terminal 3 of P1.

Test equipment	Technical manual	Common name
1 Test set 1-199.	TM 11-2604	Test set.
2 Multimeter TS-352/U.	TM 11-5527	Multimeter.
1 Transformer, Variable Power CN-16/U.	-----	Variable transformer.
1 Electric Light Assembly MX-1292/PAQ.	TM 11-5540	Electric light assembly.

3-4 Visual Inspection

a. Carefully inspect the circuit elements in the power supply before starting to troubleshoot the equipment. In many cases, the cause of the trouble is a broken wire, overheated resistor, or some similar defect. Since these faults can often be observed during a visual check, complex troubleshooting techniques may be avoided. Inspect the power supply for evidence of physical damage.

- (1) Look for damaged insulation on the wires and see that all soldered joints are secure.
- (2) See that the power plug is securely attached and that the prongs are not bent, corroded, or otherwise damaged.
- (3) Inspect the resistors for signs of overheating, and see that capacitors

and rectifier stacks are free of dust, dirt, and corrosion.

- (4) Remove each plug-in unit and inspect the plugs and the jacks' from which each unit has been disconnected. See that the contacts are clean and that no parts are damaged.
- (5) See that all fastenings are secure.

b. If the cause of trouble cannot be visually detected, it is then necessary to use the troubleshooting chart (para 3-5) and the plug-in unit tinting procedures (para 3-6).

3-5. Troubleshooting Chart

The chart below is based on the operational portion of the quarterly maintenance services and inspection chart given in TM 11-5805-239-12. Make all continuity checks with Multimeter TS-352/U, using the appropriate resistance range.

Item No	Indication	Probable trouble	Procedure
1	No output at any output terminal of terminal board TB1.	No ac power. Blown ac input fuse F2. Faulty ac plug P3. Faulty ac power cord. Defective ac power cord connations.	Check the input ac voltage at the ac power source, using the ac voltmeter section of Multimeter TS-352/U. Check continuity of F2. Replace F2 if it is open. Check to see that the prongs of P3 are not broken or bent. Replace the plug if defective. Check continuity of the ac power cord. Replace the ac power cord if defective Check for secure connections. Resolder loose or broken connections.
6	Dc blown-fuse indicator lamp lights.	Blown or missing dc output fuse F1. Defective plug-in unit.	Cheek continuity of fuse F1. Replace if open. Perform the checks outlined in paragraph 3-6. If the plug-in unit is not repairable, replace with a good one.

Item No.	Indication	Probable trouble	Procedure
8	Dc output varies erratically y as output control is rotated	Faulty output control rheostat.	Remove the plug-in unit and check continuity of resistor R3 while slowly rotating the control knob. Replace R3 if resistance does not vary smoothly.

3-6 Isolating Trouble Within Plug-in Unit

a. General. When trouble has been localized to a plug-in unit either through operational checks or the use of the troubleshooting chart, isolate the defective part by making voltage or resistance measurements.

Caution: Before attempting to perform voltage and resistance measurements, review paragraphs 3-1 through 3-5. Carefully follow instructions and observe the notes on the reference figures; carelessness may cause more troubles in the equipment and make troubleshooting more difficult.

Warning: In power supplies that do not have MWO 11-5805-239-35/1 applied, capacitor C1 will be fully charged to the dc output voltage. Use a test lead with an alligator clip to discharge C1 as follows: Attach the alligator clip to the short probe, and clamp the alligator clip to terminal 4 of plug P1. Place one hand in your pocket and touch terminal 3 of P1 with the long probe.

b. Testing Resistor R1. Check continuity between terminals 1 and 2 of plug P1. The resistance should be 100 ohms (\pm 10 percent). Replace the resistor if the value is not within these limits.

c. Testing Resistor R2. Check continuity between terminals 7 and 8 of plug PI. The resistance should be 5 ohms (\pm 10 percent) (10 ohms in PP-1209B/FG and PP-1209C/FG). Replace the resistor if it is not within these limits.

d. Testing Filter Capacitor C1. Unsolder one lead of bleeder resistor R4. Use a low-resistance range of Multimeter TS-352/U to check capacitor C1 for a short circuit. If the capacitor is, not short-circuited, use a source of dc voltage not exceeding 150 volts to make

a dielectric breakdown test. The output of one of the other plug-in units can be used. Use the 250-volt dc range of the TS352/U when making the following test:

- (1) Connect a test lead to the positive side of the voaltge supply, and another test lead to the negative side. Touch the positive lead to terminal 4 of plug P1, and the negative lead to terminal 3. Keep the leads in contact for approximately 2 seconds; this will charge a good capacitor. Remove the test leads from terminals 3 and 4 of plug P1. Remove the test leads from the power supply.
- (2) After about 1 minute, touch the positive lead of the voltmeter of the TS-352/U to terminal 4 of plug P1, and the negative lead to terminal 3. If the capacitor is satisfactory, the voltmeter needle will jump to a reading of approximately one-half of the applied dc voltage, and slowly return to zero. A weak kick of the needle indicates a faulty capacitor. Replace a defective capacitor while carefully observing polarity.

e. Testing of Selenium Rectifiers. To test the selenium rectifiers on Power Supply PP-1209/FG, proceed as follows:

- (1) Remove the plug-in unit to be tested from the main chassis assembly.
- (2) Use the ohmmeter section of Multimeter TS-352/U to check the forward-reverse resistance ratio of the selenium rectifier. Connect the black test lead of the TS-352/U to terminal 5 of plug P1, and the red test lead to terminal 6 of plug P1. Select the resistance range on the TS-352/U

which will give a center-scale reading. Note the resistance value.

- (3) Reverse the ohmmeter connections to plug P1 and select the resistance range that will give a center-scale reading. Note the resistance value. One value should be at least 1,000 times the other. Replace a rectifier that has a resistance ratio much lower than 1,000 to 1.
- (4) Repeat the above test procedure for each plug-in unit to be tested.

Warning: The failure of selenium rectifiers can result in the liberation of poisonous fumes and deposit of poisonous selenium compounds. If a rectifier stack burns or area over, provide adequate ventilation immediately. Avoid inhaling the fumes, and do not handle the rectifier until it has cooled.

f. Testing of Silicon Rectifier. To test the silicon rectifiers in Power Supplies PP-1209A/

FG, PP-1209B/FG, and all models of P P - 1209/FG, proceed as follows:

- (1) Remove the plug-in unit to be tested from the main chassis assembly.
- (2) Use the ohmmeter section of Multi-meter TS-352/U to check the forward-reverse resistance ratio of the silicon rectifier. Connect the black test lead of the TS-352/U to terminal 5 of plug P1, and the red test lead to terminal 6 of plug P1. Select the resistance range on the TS-352/U which will give a center-scale reading. Note the resistance value.
- (3) Reverse the ohmmeter connections to plug P1 and select the resistance range that will give a center-scale reading. Note the resistance value. One value should be at least 10 times the other. Replace a rectifier that has a resistance ratio lower than 10 to 1.
- (4) Repeat the above test procedure for each plug-in unit to be tested.

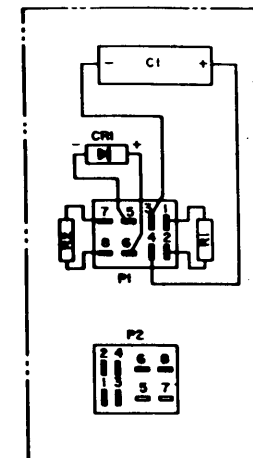
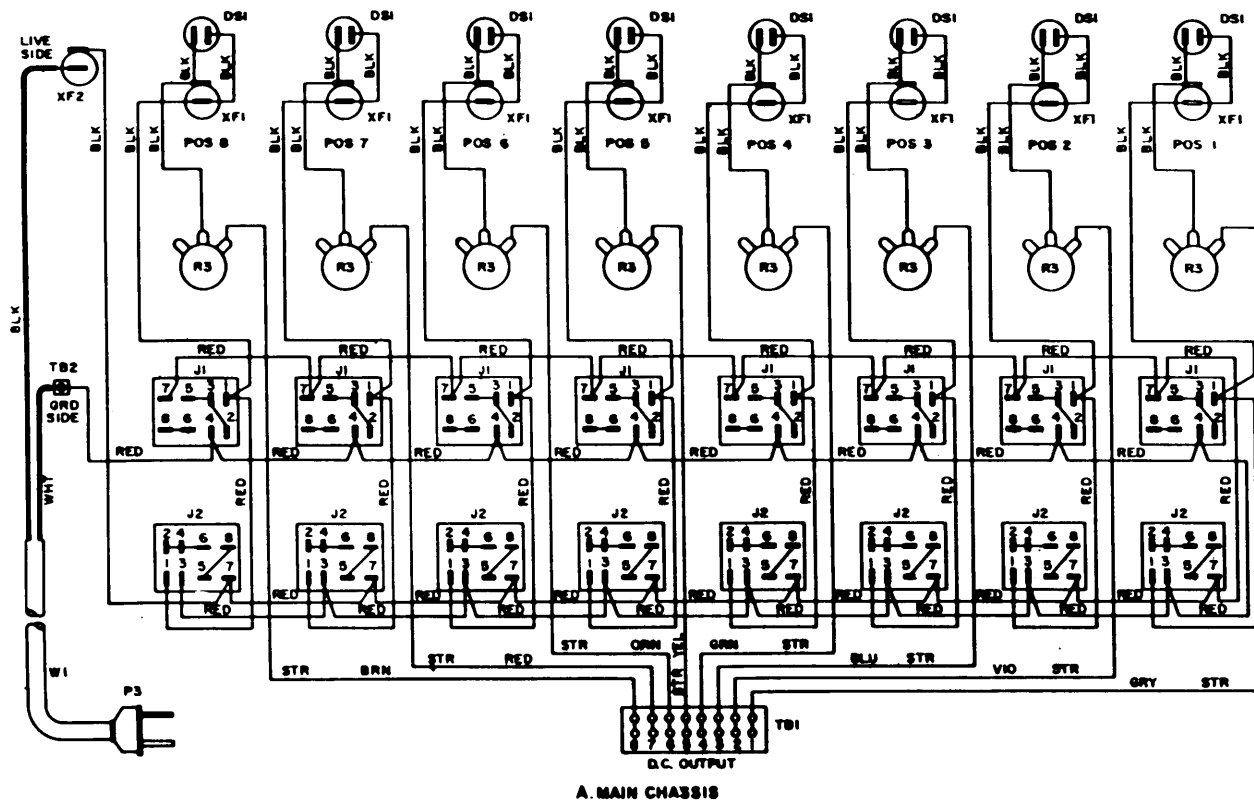

B. PLUG-IN UNIT

NOTES:

1. ALL WIRING IS #20 AWG SOLID CONDUCTOR UNLESS SPECIFIED STRANDED (STR).
2. ALL PLUG-IN UNITS WIRED AS SHOWN IN B. PLUG P2 OF PLUG-IN UNITS IS UNWIRED.
3. PLUG-IN UNITS THAT HAVE BEEN MODIFIED IN ACCORDANCE WITH WROH-5806-239-35/L, RESISTOR R4 IS CONNECTED IN PARALLEL WITH CAPACITOR C1 BETWEEN CONTACTS 3 AND 4 OF PLUG P1.

TM5806-239-35-3

Figure 3-1. Power Supply PP-1209B/FG, wiring diagram.

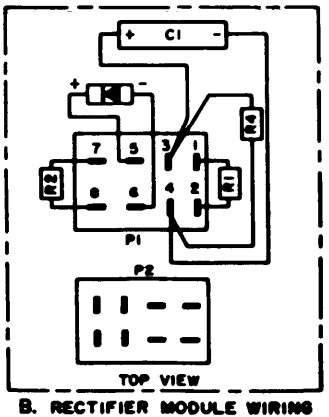
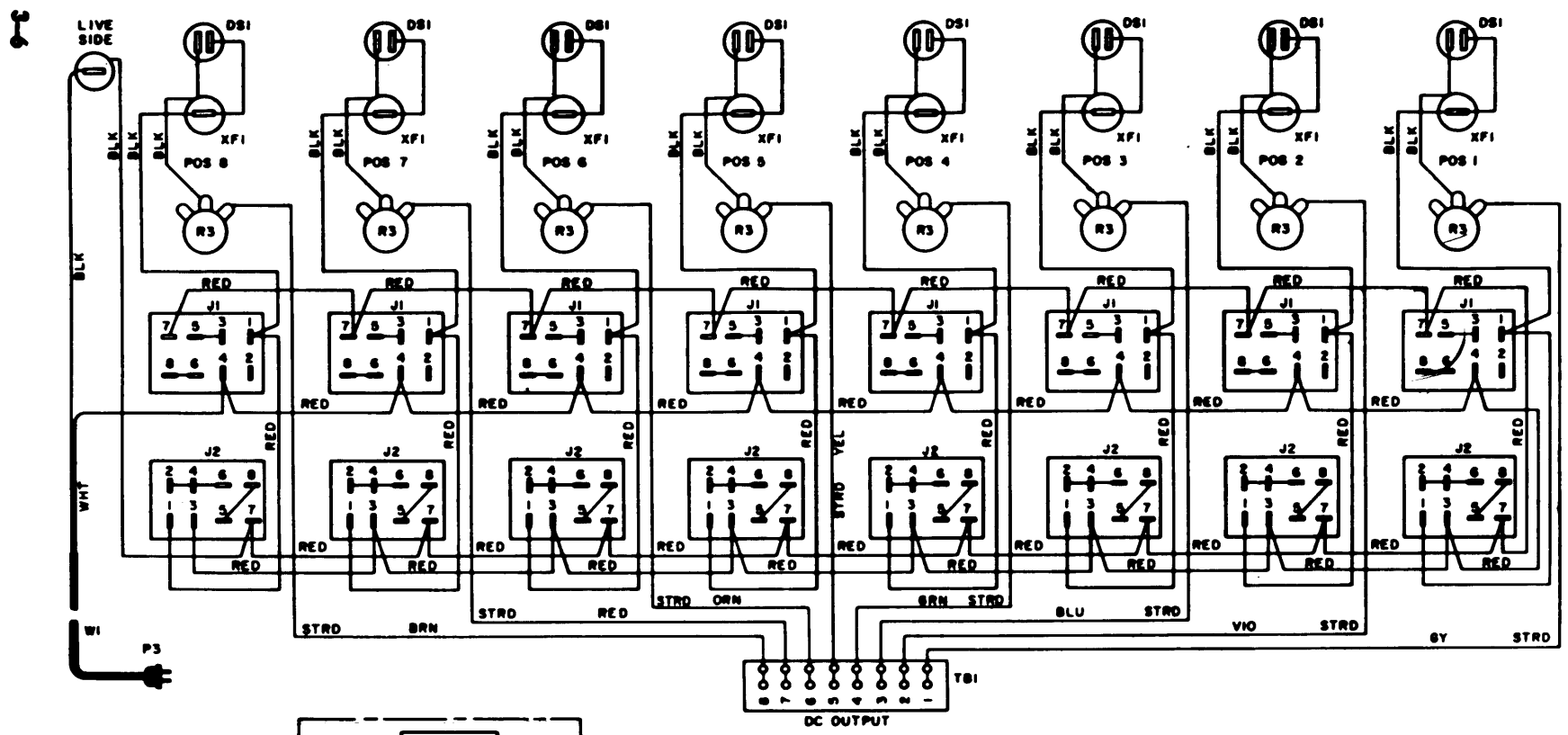

A. PANEL WIRING

NOTES:

1. ALL WIRE TO BE 22 GAGE SOLID CONDUCTOR EXCEPT AS NOTED.
2. INSULATED SLEEVING REQUIRED ON MODULE WIRING.

Figure 3-2. Power Supply PP-1209C/FG, Order No. 10437-PP-61-C2-C2, wiring diagram

Section II. REPAIR

3-7. General Parts Replacement Techniques

(fig. 3-1, 3-2. and 5-1)

Most of the parts of Power Supply PP-1209(*)/FG can be reached and replaced without special procedures. Whenever a part has been removed or any wires have been disconnected, refer to the appropriate wiring diagram when making reconnection. See that all fastenings are replaced securely. After a repair has been completed, test the equipment (para 3-8) before returning it to service. The following precautions apply specifically to this power supply.

a. Capacitor C1 is an electrolytic capacitor; proper polarity must be observed when placing it into a circuit.

b. When replacing rectifier CR1, observe the polarity. (The end with the positive marking is the semiconductor cathode.)

c. Use a pencil-type soldering iron when soldering or unsoldering the component parts. When the repair is completed, restore all wires to their original dress.

3-8. Testing Repaired Equipment

Repaired equipment should be tested for proper operation. Refer to paragraph 4-6 for the PP-1209 (*)/FG test procedure.

CHAPTER 4 GENERAL SUPPORT TESTING PROCEDURES

4-1. General Support Testing Procedures

(fig, 4-1)

a. Testing procedures are prepared for use by Signal Field Maintenance Shops and Signal Service organizations responsible for general support maintenance to determine the acceptability of repaired electronic equipment. These procedures set forth specific requirements that repaired electronic equipment must meet before it is returned to the using organization. The testing procedures may also be used as a guide to test equipment repaired by direct support personnel if the proper tools and test equipment are available. A summary of the performance is given in paragraph 4-7.

b. Comply with the instructions preceding each chart before proceeding to the chart. Perform each step in sequence. Do not *vary the sequence*. For each step, perform all the actions required in the *Control settings* columns; then perform each specific test procedure and verify it against its performance standard.

4-2. Test Equipment and Other Equipment

All test equipment, tools, and materials required to perform the testing procedures given in this chapter are listed in the charts below. These are authorized under TA 11-17 and TA 11-100 (11-17), or TOE 11-158D and TA 11-101 (11-158), or are repair part items of the subject equipment authorized for stockage at general support.

a. *Test Equipment.*

Nomenclature	Federal stock No.	Technical manual
Test Set I-199(*) ^a Multimeter TS-352(*)U ^b (2 EA).	6625-229-1045	TM 11-2604.
Transformer, Variable Power CN-16(*)/U ^c .	6625-242-5023	TM 11-5527.
Electric Light Assembly MX-1292/PAQ.	5950-233-2086	None.
	6695-537-4470	TM 11-5540.

a Indicates Test Set 1-199 or I-199-A.

b Indicates Multimeter TS 352/U, TS-352A/U or TS 352B/U.

c Indicates Transformer, Variable Power, CN 16/U or CN-16A/U.

b. *Other Equipmmt.*

Nomenclature	Federal stock No	Technical manual
Test Lead Set CX-1331A/U-----	6625-395-9313	None.

4-3. Test Facilities

A primary source of power at 115 volts ac, 60 cps, single phase is required for the tests. Voltages between 105 and 125 may be used, provided adjustments are made for those tests.

4-4. Modification Work Orders

The performance standards listed in the tests (para 5-2) are based on the assumption that the modification work order (MWO) listed below has been performed. A listing of current MWO's will be found in DA Pam 310-4.

MWO No.	Date	Priority	Maintenance Category	Location of MWO markings	Remarks
MWO 11-5805-239-35/1	14 Mar 63	NORMAL	Direct support	Below POSITIVE label of subassembly and below fuse on front panel.	None.

4-5. Physical Tests and Inspection

a. *Test Equipment and Materials.* Electric Light Assembly MX-1292/PAQ.

b. *Test Connections and Conditions.* Prepare the MX-129 2/PAQ for use by connecting the mercury-vapor lamp and installing the wide transmission filter.

c. *Procedure.*

Step No.	Control settings		Test procedure	Performance standard
	Test equipment	Equipment under test		
1	None-----	Controls may be in any position.	<p>a. Inspect case, chassis, panel, and all plug-in units for damage or missing parts, and for condition of paint.</p> <p><i>Note:</i> Touchup painting is recommended instead of refinishing whenever practical; screwheads, binding posts, receptacles, and other plated parts will not be painted or polished with abrasives.</p> <p>b. Inspect all controls and mechanical assemblies for loose or missing screws, bolts, and nuts.</p> <p>c. Inspect all plug-in units for damage to parts, and to see that plug prongs are clean and straight and can be easily and firmly inserted in their mating jacks.</p> <p>d. Inspect all connectors, sockets, receptacles, and fuseholders for looseness, damage, or missing parts.</p>	<p>a. No damage evident or parts missing. External surfaces intended to be painted will not show bare metal. Panel lettering will be legible.</p> <p>b. Screws, bolts, and nuts will be tight; none missing.</p> <p>c. All parts of plug-in units are sound and clean. Plug prongs are clean and straight and withdrawal of plug-in units is performed without difficulty.</p> <p>d. No loose parts or damage. No missing parts.</p>
2	None-----	Controls may be in any position.	<p>a. Rotate all panel controls throughout their limits of travel.</p> <p>b. Transpose each plug-in from POSITIVE to NEGATIVE.</p>	<p>a. Controls will rotate freely, without binding or excessive looseness.</p> <p>b. Plug-in units will fit firmly and easily.</p>
3	<p>MX-1292/PAQ</p> <p>a. Connect mercury vapor lamp</p> <p>b. Install wide transmission filter in lamp.</p>	Controls may be in any position.	<p>Turn on mercury-vapor lamp and expose the portion of the equipment that has been repaired or disturbed, to the direct rays of the lamp.</p>	<p>All repaired or disturbed electrical components and chassis surfaces will be covered with varnish. There must be no varnish on switch contacts or moving parts of mechanical assemblies.</p> <p><i>Note.</i> Moisture-fungiproofing varnish glows gray green under rays of mercury-vapor lamp.</p>

TM 11-5805-239-35

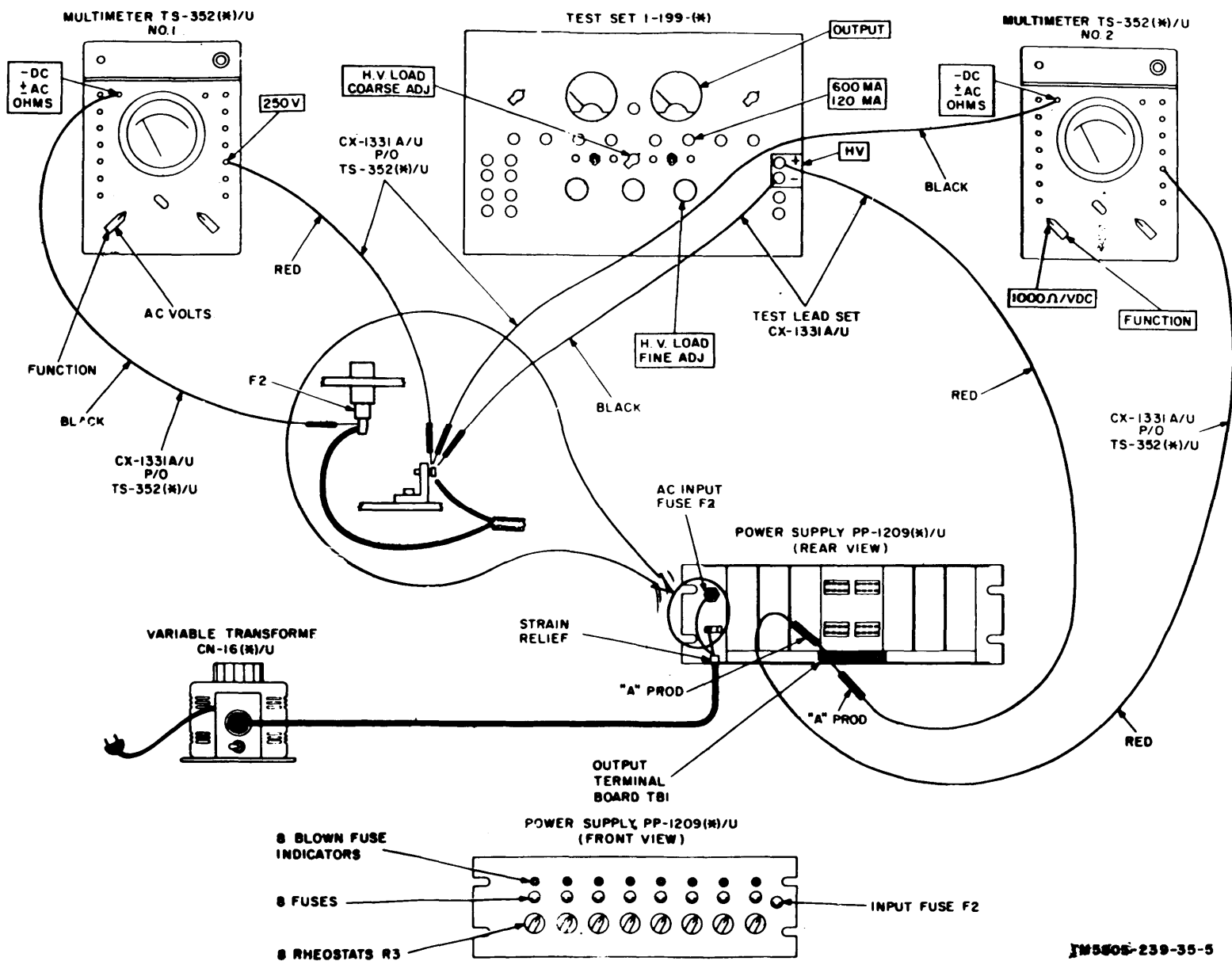

Figure 4-1. Output voltage test, connection diagram.

4-6. Output Voltage Test
(fig. 4-1)

a. Test Equipment and Materials.

Multimeter TS-352(*)/U, two each.

Test Set I-199(*)

Transformer, Variable Power CN-16(*)/U.

Test Lead Set CX-1331A/U.

b. Test Connections and Conditions. Connect the equipment as shown in figure 4-1. Connect the ac input plug to 115-volt, 60-cps, single-phase, ac power source, and adjust the CN-16(*)/U to indicate 115 volts on TS-352(*)/U No. 1. Insert all plug-in units with the word POSITIVE at the top.

Note: It may be necessary to adjust the ac voltage to 115 volts before observing each dc voltage output on TS-352(*)/U No. 2.

c. Procedure.

Step No.	Control settings		Test procedure	Performance standard
	Test equipment	Equipment under test		
1	<p>I-99(*): H.V. Load COARSE ADJ: OFF.</p> <p>TS-352(*)/U No. 1: FUNCTION switch: AC VOLTS.</p> <p>TS-352(*)/U No. 2: FUNCTION switch: 1000Ω/VDC.</p>	<p>All R3 rheostats: Maximum clockwise rotation (100).</p>	<p>a. Connect A prod to terminal No. 1 of output terminal board TB1 and observe dc voltage and polarity on TS-352(*)/U No. 2.</p> <p>b. Repeat a above for remaining seven terminals (2 thru 8) of output terminal board TB1.</p> <p>c. Same as a above, except all plug-in units with word NEGATIVE to top. Reverse leads of CX-1331A/U (part of TS-352(*)/U red or black) on multimeter TS-352(*)/U No. 2 and reverse leads on HV terminals of I-199.</p> <p>d. Repeat c above for remaining seven terminals (2 thru 8) of output terminal board TB1.</p>	<p>a. Between 140 and 170 volts dc, positive with respect to ground.</p> <p>b. Same as a above.</p> <p>c. Same as a above, except voltage is negative with respect to ground.</p> <p>d. Same as c above.</p>
2	<p>I-199(*): H.V. LOAD COARSE ADJ and H.V. LOAD FINE ADJ: As stated in test procedure. OUTPUT switch: MA.</p> <p>TS-352(*)/U No. 1:</p> <p>Same as in step No. 1 above. TS-352(*)/U No. 2:</p> <p>Same as in step No. 1 above.</p>	<p>Same as in step No. 1.</p>	<p>a. Reinsert all plug-in units and connect CX-1331A/U (part of TS-352(*)/U) as indicated in step No. 1a. Turn H.V. LOAD COARSE ADJ and H.V. LOAD FINE ADJ of I-199(*) until OUTPUT meter indicates 10 ma. (Depress OUTPUT 600MA 120MA switch to read current on 120-ma scale for a more accurate indication.) Observe dc voltage on TS-352(*)/U No. 2.</p> <p>b. Repeat a above for remaining seven terminals (2 thru 8) of output terminal board TB1.</p> <p>c. Repeat a above, except that OUTPUT meter should indicate 50 ma. Observe dc voltage on TS-352(*)/U No. 2.</p> <p>d. Repeat c above for remaining seven terminals (2 thru 8) of output terminal.</p> <p>e. Repeat a above, except that OUTPUT meter should indicate 100 ma. Observe dc voltage on TS-352(*)/U No. 2.</p> <p>f. Repeat e above for remaining seven terminals (2 thru 8) of output terminal board TB1.</p> <p>During voltage observation in step No. 2e and f above, slowly turn rheostat R3 counterclockwise of 0 while observing voltage on TS-352(*)/U No. 2.</p>	<p>a. Between 135 and 165 volts dc, positive with respect to ground.</p> <p>b. Same as a above.</p> <p>c. Between 125 and 153 volts dc, positive with respect to ground.</p> <p>d. Same as c above.</p> <p>e. Between 117 and 141 volts dc, positive with respect to ground.</p> <p>f. Same as e above.</p>
3	<p>Same as in step No. 2.</p>	<p>Same as in step No. 1.</p>	<p>During voltage observation in step No. 2e and f above, slowly turn rheostat R3 counterclockwise of 0 while observing voltage on TS-352(*)/U No. 2.</p>	<p>Voltage drops gradually and smoothly from maximum to minimum value. There are no sudden drops or movements of pointer.</p>

4-7. Test Data Summary

Personnel may find it convenient to arrange the check list like that shown below. Unless otherwise shown, all voltages listed are dc positive with respect to ground.

Condition	Performance standard		
	Min	Max	
1. Plug-in unit POSITIVE up. No load on terminal No.	1	140	170
	2	140	170
	3	140	170
	4	140	170
	5	140	170
	6	140	170
	7	140	170
	8	140	170
2. Plug-in units, NEGATIVE up. No load on terminal No.	1	140 ^a	170 ^a
	2	140 ^a	170 ^a
	3	140 ^a	170 ^a
	4	140 ^a	170 ^a
	5	140 ^a	170 ^a
	6	140 ^a	170 ^a
	7	140 ^a	170 ^a
	8	140 ^a	170 ^a
3. Plug-in units, POSITIVE up. 10-ma load on terminal No.	1	135	165
	2	135	165
	3	135	165
	4	135	165
	5	135	165
	6	135	165
	7	135	165
	8	135	165
4. Plug-in units, POSITIVE up. 50-ma load on terminal No.	1	125	155
	2	125	155
	3	125	155
	4	125	155
	5	125	155
	6	125	155
	7	125	155
	8	125	155
5. Plug-in units, POSITIVE up. 100-ma load on terminal No.	1	117	141
	2	117	141
	3	117	141
	4	117	141
	5	117	141
	6	117	141
	7	117	141
	8	117	141

CHAPTER 5 DEPOT INSPECTION STANDARDS

5-1. Applicability of Depot Inspection Standards

The tests outlined in this chapter are designed to measure the performance capability of a repaired equipment. Equipment that is to be returned to stock should meet the standards given in these tests.

5-2. Applicable References

a. Repair Standard. Applicable procedures of the depot performing this test and its general standards for repaired electronics equipment given in TB SIG **355-1**, TB SIG 355-2, and TB SIG 355-3 form a part of the requirements for testing this equipment.

b. Technical Publications. The following technical publications are applicable to this equipment:

Title	Number	Date
Operator and Organizational Maintenance Manual, Power Supplies PP-1209/FG, PP-1209A/FG, PP-1209B/FG, and PP-1209C/FG.	TM 11-6805-239-12	4 October 1962
Operator and Organizational Maintenance Repair Parts and Special Tools List, Power SUPPLIES PP-1209/FG, PP-1209A/FG, PP-1209B/FG and PP-1209C/FG.	TM 11-5805-239-12P	23 July 1962
Field and Depot Maintenance Repair Parts and Special Tool List Power Supplies PP-1209/FG, PP-1209A/FG, PP-1209B/FG and PP-1209C/FG.	TM 11-5805-239-35P	2 April 1962

c. Modification Work Orders. Perform all MWO's pertaining to this equipment before making the tests specified. DA PAM 310-4 lists all available MWO's.

5-3. Test Facilities Required

The following equipment, or suitable equivalent, will be employed in determining compliance with the requirements of this specific standard.

a. Test Equipment.

Equipment	Stock No.	Qty reqd	Applicable literature
Multimeter TS-352/U	6625-242-5023	2	TM 11-6627

b. Additional Equipment.

Equipment	Stock No.	Qty reqd
Resistor, variable, 10,000 ohms, 160 watts.	5905-196-2316	2

5-4. General Test Requirements

a. Indicator lamps shall be checked to insure proper setting and security.

b. Each of the eight plug-in units shall be removed and the mountings checked to see that the moulded shells are not cracked or broken, and that the plug-in prongs are not bent. When the plug-in units are replaced, check to see that the prongs of the plugs enter smoothly between the contact fingers in the receptacles, and without the need of undue force.

c. Prepare a 20,000-ohm variable resistor by connecting the two 10,000-ohm variable resistors in series.

5-5. Operational Test

a. Connect the ac input cable to a power source of 116 volts, 60 cps, single phase ac. If a 115-volt ac power source is not available, use any voltage between 105 and 125 volts and make allowance when making the tests below.

- (1) Install a plug-in unit in position 1 on the power supply panel, with the word POSITIVE at the top.
- (2) Measure the dc output between terminal 1 on terminal board TB1 and ground. The reading should be approximately 155 volts positive with respect to ground.
- (3) Remove the plug-in unit and reinstall it with the word NEGATIVE at the top, and repeat the above test. The voltage should now be 166 volts negative with respect to ground.
- (4) With no load connected, turn the knob of the output control rheostat of the position under test to 100 on the dial.
- (5) Remove the plug-in unit and connect a variable load (0 to 20,000 ohms) and milliammeter in series between terminal 1 of terminal board TB1 and ground. Turn the variable load to its maximum resistance before completing the connection to ground. Reinstall the plug-in unit.

- (6) Connect a dc voltmeter across the variable load.
- (7) Vary the load in steps of 10 ma from 10 to 100 ma, and take a voltage reading at each step. These readings should approximate the values in the chart below with suitable allowances for possible variations in the input voltage,

Dc output	
Milliamperes	Volts (approx)
0	166
10	160
20	146
30	144
40	142
60	189
60	197
70	196
80	188
90	181
100	129

Note. Aged selenium rectifiers in a unit will result in slightly lower output voltage readings as compared with new selenium rectifiers.

- (8) Repeat the test given in (1) and (2) above for each of the dc output positions.
- (9) Maintain the equipment connections specified above. With the output control at maximum clockwise position (100), adjust the 20,000-ohm variable load for 100 ma as indicated on the TS-352/U. The voltage across the variable load should vary smoothly as the panel output control is varied from 100 to 0 and back to the 100-ohm position

Caution: Do not exceed 100 ma at any time.

b. Plug-in units that pass the above tests may be returned to service.

APPENDIX REFERENCES

Following is a list of applicable references available to direct support, general support, and depot maintenance personnel of Power Supply PP-1209(*)/FG.

DA Pam 310-4	Index of Technical Manuals, Technical Bulletins, Supply Manuals (Types 7, 8, and 9), Supply Bulletins, Lubrication Orders, and Modification Work Orders.
MWO 11-5805-239-35/1	Modification of Power Supply PP-1209B/FG and Subassemblies, FSN 5805-885-5981, to Eliminate a Shock Hazard.
TA 11-17	Signal Field Maintenance Shops.
TA 11-100(11-17)	Allowances of Signal Corps Expendable Supplies for Signal Field Maintenance Shops.
TA 11-101(11-158)	Allowances of Signal Corps Expendable Supplies for Signal Depot Company.
TB SIG 355-1	Depot Inspection Standard for Repaired Signal Equipment.
TB SIG 355-2	Depot Inspection Standard for Refinishing Repaired Signal Equipment.
TB SIG 355-3	Depot Inspection Standard for Moisture and Fungus Resistant Treatment.
TM 11-2604	Test Sets I-199 and I-199A.
TM 11-5527	Multimeters TS-352/U, TS-352A/U, and TS-352B/U.
TM 11-5540	Electric Light Assembly MX-1292/PAQ.
TM 11-5805-239-12	Operator and Organizational Maintenance Manual: Power Supplies PP-1209/FG, PP-1209A/FG, PP-1209B/FG, and PP-1209C/FG.
TM 11-5805-239-12P	Operator and Organizational Maintenance Repair Parts and Special Tool Lists: Power Supplies PP-1209/FG, PP-1209A/FG, PP-1209B/FG, and PP-1209C/FG.
TM 11-5805-239-35P	Field and Depot Maintenance Repair Parts and Special Tool Lists: Power Supplies PP-1209/FG, PP-1209A/FG, PP-1209B/FG, and PP-1209C/FG.
TM 38-750	Army Equipment Record Procedures.
TOE 11-158D	Signal Depot Company.

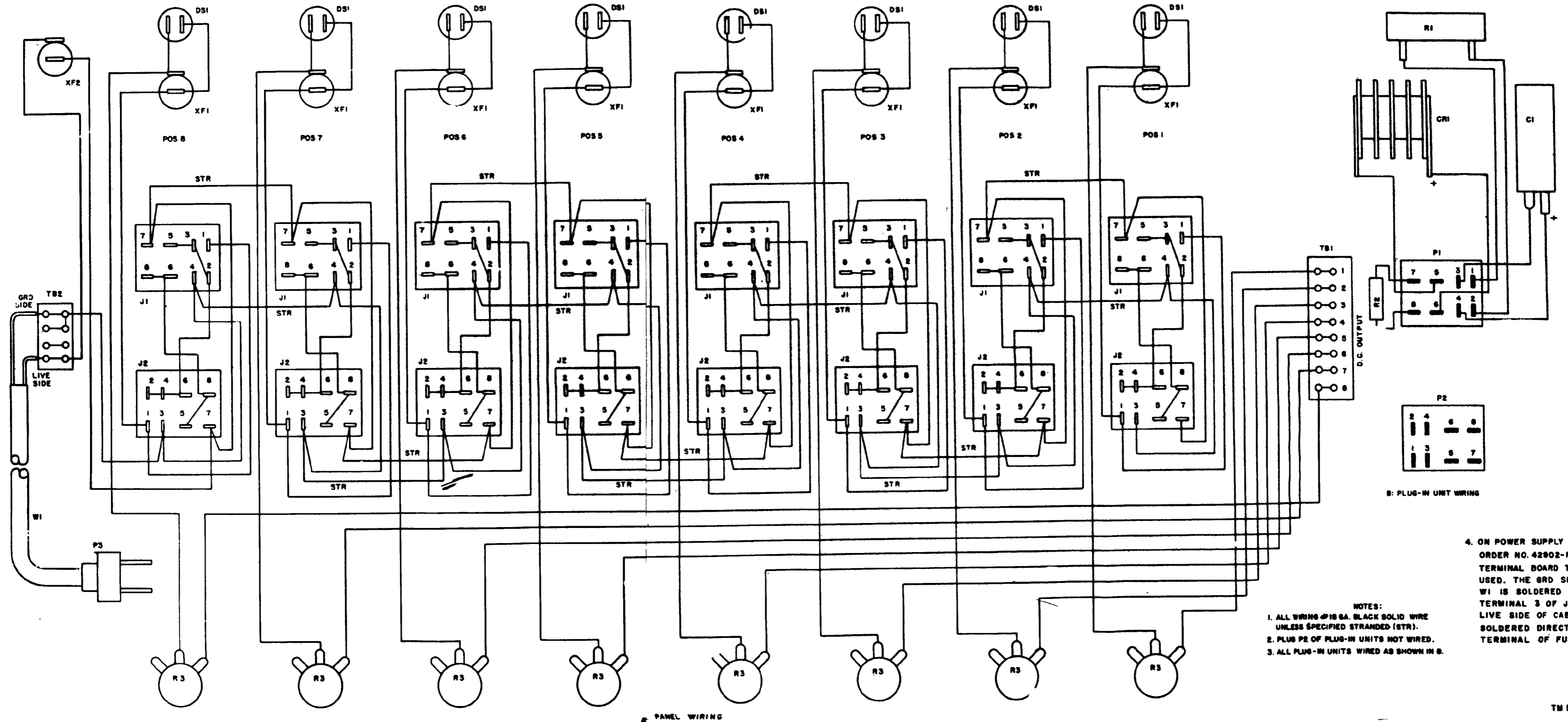

- NOTES:
1. ALL WIRING #18 GA. BLACK SOLID WIRE UNLESS SPECIFIED STRANDED (STR).
 2. PLUS P2 OF PLUG-IN UNITS NOT WIRED.
 3. ALL PLUG-IN UNITS WIRED AS SHOWN IN B.
 4. ON POWER SUPPLY PP-1209/FG, ORDER NO. 42902-PHILA-57, TERMINAL BOARD TB2 IS NOT USED. THE GRD SIDE OF CABLE W1 IS SOLDERED DIRECTLY TO TERMINAL 3 OF JACK J2; THE LIVE SIDE OF CABLE W1 IS SOLDERED DIRECTLY TO THE TERMINAL OF FUSE HOLDER XF2.

PANEL WIRING

B: PLUG-IN UNIT WIRING

Figure 5-1. Power Supply PP-1209/FG, Order No. 26891-Phila-55, wiring diagram.

TM 5805-239-35-2

By Order of the Secretary of the Army:

HAROLD K. JOHNSON,
General, United States Army,
Chief of Staff.

Official:

J. C. LAMBERT,
Major General, United States Army,
The Adjutant General

Distribution:

Active Army:

USASA (2)	507th USASA Gp (5)	Ft Knox (12)
CNGB (1)	508th USASA Gp (5)	Ft Devens (5)
CC-E (7)	318th USASA Bn (5)	Army Dep (2) except
Dir of Trans (1)	319th USASA Bn (5)	LBAD (14)
Cof Engrs (1)	320th USASA Bn (5)	SAAD (30)
TSG (1)	102nd USASA Det (5)	TOAD (14)
CofSptS (1)	177th USASA Co (5)	FTWOAD (10)
USACDCEA (1)	182nd USASA Co (5)	LEAD (7)
USACDCCBRA (1)	183rd USASA Co (5)	SHAD (3)
USACDCCEA (1)	184th USASA Co (5)	NAAD (5)
USACDCCEA	1st USASA Fld Sta (5)	SVAD (5)
Ft Huachuca (1)	2nd USASA Fld Sta (5)	CHAD (9)
USACDOA (1)	3rd USASA Fld Sta (5)	ATAD (10)
USACDCQMA (1)	4th USASA Fld Sta (5)	GENDEP (OS) (2)
USACDCTA (1)	5th USASA Fld Sta (5)	Sig Sec, GENDEP (OS) (5)
USACDCADA (1)	9th USASA Fld Sta (5)	Sig Dep (OS) (12)
USACDCARMA (1)	12th USASA Fld Sta (5)	Sig Fld Maint Shops (2)
USACDCAVNA (1)	13th USASA Fld Sta (5)	AMS (1)
USACDCARTYA (1)	14th USASA Fld Sta (5)	USAERDAA (2)
USACDCSWA (1)	16th USASA Fld Sta (5)	USAERDAW (13)
USAMC (6)	Svc Colleges (2)	MAAG, Pakistan (5)
USCONARC (5)	Br Svc Sch (2)	USACRREL (2)
ARADCOM (6)	USATC AD (2)	Units org under fol TOE:
ARADCOM Rgn (2)	USATC Armor (2)	11-67 (2)
OS Maj Comd (4)	USATC Engr (2)	11-97 (2)
LOGCOMD (2)	USATC Inf (2)	11-98 (2)
USAMICOM (4)	USASTC (2)	11-117 (2)
USASMC (2)	WRAMC (1)	11-12?? (2)
USASCC (4)	Army Pic Cen (2)	11-166 (2)
USAECOM (80)	USACDCEC (10)	11-167 (2)
USASPTCP (11)	Instl (2) except	11-168 (2)
MDW (1)	Ft Monmouth (70)	11-500
Armies (2)	Ft Gordon (10)	(AA-AC) (NC)
Corps (2)	Ft Huachuca (10)	11-587 (2)
USAC (8)	WSMR (6)	11-597 (2)
11th Air Aslt Div (8)	Ft Carson (21)	

NG and USAR: None

For explanation of abbreviations used see AR 320-60.

* U.S. GOVERNMENT PRINTING OFFICE : 1987 o - 201-421 (71018)

RECOMMENDED CHANGES TO EQUIPMENT TECHNICAL PUBLICATIONS



THEN...JOT DOWN THE DOPE ABOUT IT ON THIS FORM. CAREFULLY TEAR IT OUT, FOLD IT AND DROP IT IN THE MAIL.

SOMETHING WRONG WITH PUBLICATION

FROM: (PRINT YOUR UNIT'S COMPLETE ADDRESS)

DATE SENT

PUBLICATION NUMBER

PUBLICATION DATE

PUBLICATION TITLE

BE EXACT PIN-POINT WHERE IT IS

PAGE NO.

PARA-GRAPH

FIGURE NO.

TABLE NO.

IN THIS SPACE, TELL WHAT IS WRONG AND WHAT SHOULD BE DONE ABOUT IT.

TEAR ALONG PERFORATED LINE

PRINTED NAME, GRADE OR TITLE AND TELEPHONE NUMBER

SIGN HERE

